

DOCUMENT RESUME

ED 137 271

SP 010 909

AUTHOR Copeland, Willis D.  
 TITLE The Nature of the Relationship Between Cooperating Teacher Behavior and Student Teacher Classroom Performance.  
 PUB DATE 77  
 NOTE 12p.; Paper presented at the annual meeting, American Educational Research Association (New York, New York, April 4-8, 1977)  
 EDRS PRICE MF-\$0.83 HC-\$1.67 Plus Postage.  
 DESCRIPTORS \*Classroom Environment; Classroom Research; \*Cooperating Teachers; \*Skill Development; \*Student Teachers; Teacher Behavior; \*Teacher Education; \*Teaching Styles; Transfer of Training

ABSTRACT

This report presents data obtained from an experiment in student teaching behaviors designed to suggest an explanation for the previously detected relationship between cooperating teacher behavior and student teacher utilization of skills acquired during microteaching training. In order to determine if one or the other explains more effectively the actual use of the learned target skill, two hypotheses were tested: (1) cooperating teachers utilization of the target skill would serve as a model of performance for the student teacher; and (2) the ecological system of the classroom acts as a supporter and promoter of the target skill. Thirty-two randomly selected first-year graduate students in an elementary education credentials program underwent microteaching training, one-half in situations where the cooperating teacher made high use of the target skill (asking probing questions) and one-half in situations where low use of the skill was made. After the microteaching phase, each group was divided in half and recombined to form two new groups with opposing experiences. The two new groups then underwent a one-week teaching experience, one in classroom settings accustomed to use of the target skill, the other in classrooms where the skill was little used. Observation and analysis revealed that, while members of both groups who had undergone microteaching in the target skill high usage classes initially made use of the skill, continuation of the usage was maximum in those classrooms where the students were accustomed to previous teacher utilization of the skill and could respond appropriately. Thus it would seem that the second hypothesis is a more effective explanation for target skill usage. (MB)

\*\*\*\*\*  
 \* Documents acquired by ERIC include many informal unpublished \*  
 \* materials not available from other sources. ERIC makes every effort \*  
 \* to obtain the best copy available. Nevertheless, items of marginal \*  
 \* reproducibility are often encountered and this affects the quality \*  
 \* of the microfiche and hardcopy reproductions ERIC makes available \*  
 \* via the ERIC Document Reproduction Service (EDRS). EDRS is not \*  
 \* responsible for the quality of the original document. Reproductions \*  
 \* supplied by EDRS are the best that can be made from the original. \*  
 \*\*\*\*\*

7.13

The Nature of the Relationship Between Cooperating Teacher Behavior and Student Teacher Classroom Performance

U.S. DEPARTMENT OF HEALTH, EDUCATION & WELFARE  
NATIONAL INSTITUTE OF EDUCATION

Willis D. Copeland  
Department of Education  
University of California,  
Santa Barbara

THIS DOCUMENT HAS BEEN REPRODUCED EXACTLY AS RECEIVED FROM THE PERSON OR ORGANIZATION ORIGINATING IT. POINTS OF VIEW OR OPINIONS STATED DO NOT NECESSARILY REPRESENT OFFICIAL NATIONAL INSTITUTE OF EDUCATION POSITION OR POLICY

The current emphasis on competency based teacher education has led, in recent years, to an examination of training methods used by teacher education institutions to equip credential candidates with specific instructional skills. Microteaching (Allen, 1966) has been adopted by many institutions as an appropriate training format for those skills used during the interactive phases of teaching (Johnson, 1968). Recent research, however, has cast doubt on the assumption that participation in a microteaching training sequence will, alone, cause student teachers to exhibit, in their classroom subsequent to training, the skills which were the target of that training (Allen, McDonald & Orme, 1966; Brashear & Davis, 1970; Copeland, 1975; Copeland & Doyle, 1973; Peterson, 1973). Testing the hypothesis that this lack of subsequent exhibition of the target skills was not due to mere "forgetting" but to the systematic effect of other variables, Copeland (1977) reported that the tendency of the cooperating teacher to use the skill which was the target of microteaching training was, in his investigation, a significant variable which affected the student teacher's use of the skill subsequent to training.

This effect of the cooperating teacher on student teacher skill utilization may be explained in at least two ways. First, the cooperating

ED 137271

SP 010 909

teacher's influence may be understood in terms of social learning theory (Bandura & Walters, 1963). From this perspective it might be hypothesized that the cooperating teacher's utilization of the target skill would serve as a model of performance for the student teacher. Observing the model would positively incline the student teacher to use, in the classroom, the skill which had previously been mastered in the training laboratory.

Second, the apparent effect of the cooperating teacher on student teacher skill utilization may be understood in terms of what Doyle and Ponder (1975) have called the ecological system of the classroom, i.e., "...that network of interconnected processes and events which impinges upon behavior in the teaching environment" (p. 183; also see Bronfenbrenner, 1976). From this perspective, an increase in student teacher skill utilization is seen as a result of the student teacher's attempt to use the target skill in a classroom ecological system which is accustomed to and even supports that kind of teaching behavior. Given this orientation, it may be hypothesized that the student teacher, when attempting to use the target skill in a classroom in which exhibition of the skill is a teaching behavior which is part of the existing ecological network, will find use of the target skill easy, seemingly appropriate and productive in terms of student reaction.

The intent of the present study was to determine if one or the other of the two perspectives described above more effectively explains previously detected relationships between cooperating teacher skill utilization and student teacher classroom performance.

Method

A 2 x 2 design was used to test the relationship of the dependent variable, rate of student teacher exhibition of the target skill in the classroom subsequent to training, and the two independent variables; Variable A - Cooperating teacher provides a model of appropriate use of the target skill, and Variable B - Student teacher teaches in a classroom ecological system which is accustomed to use of the target skill.

Subjects. Thirty-two first year graduate students who were candidates for elementary teaching credentials and who were enrolled in the same credential program at the University of California, Santa Barbara, were used as subjects for this investigation. The group was composed of 23 females and 9 males with a mean age of 25.2 (s.d. = 3.16).

Procedure. All Ss participated in a three week microteaching training program in which specific instructional skills were taught including the target skill for the present investigation - asking probing questions. The week after training ended each S began student teaching in one of two types of classrooms to which he/she had been randomly assigned. Each classroom type was characterized by one of two levels of Variable A as illustrated in Figure 1.

-----  
Insert Figure 1 here  
-----

Data Collection. During the fourth week of the Ss' second student teaching assignment of the year and four weeks after completion of microteaching training, audio recordings were made of class sessions

taught by the Ss in alternate rooms characterized by one of two levels of Variable B (See figure 1). Each S made four 15 minute recordings, no two being made on the same day. The Ss made the recordings in order to fulfill a requirement of a seminar course and no reference was made to the previously completed microteaching activity.

### Data Analysis and Results

The Ss' individual recorded sequences were transrecorded in a random order onto master tapes and the number of minutes and seconds of teacher talk in each sequence was noted. The master tapes were given to two trained raters for coding. The coding process required the raters to count the number of times that each S exhibited the target skill, asking probing questions. Each rater received two-thirds of the sequences so that one-third was coded by both raters, this for purposes of verifying interrater reliability. The correlation between raters was maintained above  $r = .823$  for the entire coding procedure.

The above process yielded scores representing the number of times the Ss exhibited the skill during each recording sequence. Each score was then divided by the number of minutes of teacher talk present in the sequence. The result represents the number of incidents of target skill exhibition per minute of teacher talk. This process was completed for each of four recordings for each S. The mean of the four scores thus derived was computed yielding a mean score for each S, hereafter referred to as the S's "skill utilization score."

The means and standard deviations of the skill utilization scores for Ss in the four treatment groups are presented in Table 1.

-----  
Insert Table 1 here  
-----

These skill utilization scores were submitted to a 2 x 2 analysis of variance in order to determine the effects of the two independent variables and their possible interaction on the Ss' performance. The results of this analysis as summarized in Table 2 indicate that Variable B, the classroom ecological system, had a significant effect on the Ss' utilization of the target skill. Variable A, the model of the target skill provided by the cooperating teacher, and the interaction of the two independent variables did not have significant effects.

-----  
Insert Table 2 here  
-----

### Discussion

The results of the present investigation suggest an explanation for the previously detected relationship between cooperating teacher behavior and student teacher utilization of skills acquired during microteaching training. The explanation revolves around the history of the cooperating teacher's behavior and the effects of that behavior on the interconnected processes and events, called by Doyle and Ponder (1975) a classroom ecological system, that are typical of the classroom. It would seem that the cooperating teacher's consistent utilization of the target skill in the classroom causes that skill to become an acceptable, appropriate and functional part of the classroom's ecological system. The pupils become

accustomed to it and develop responses to the skill's use which are appropriate. When a student teacher who has completed training in use of the target skill enters a classroom and attempts to utilize the skill, that attempt "fits" the system. The pupils are accustomed to its use and are capable of responding to it in appropriate ways. Such a "fit" in turn reinforces the student teacher's use of the skill, thereby increasing the likelihood that the skill will be utilized again in the future. On the other hand, when a student teacher attempts to utilize the target skill in a classroom where the cooperating teacher has not used it and therefore where the skill is not a part of the ecological system, such use is not appropriate for the system as it exists and is not reinforced. Thus, though the student teacher had received training in the skill, its utilization declines.

The present research has implications for the design of teacher education programs, for development of further understanding of the dynamics of the classroom, and for inquiry into the adequacy of current research paradigms relating to questions of teacher behavior and pupil performance.

References

- Allen, D.W. Microteaching: A description. Stanford University: School of Education, 1966.
- Allen, D.W., McDonald, F.J., & Orme, M.E.J. Effect of feedback and practice conditions on the acquisition of a teaching strategy. Stanford University: School of Education, 1966.
- Bandura, A., & Walters, R.H. Social learning and personality development. New York: Holt, Rinehart, & Winston, 1963.
- Brashear, R.M. & Davis, O.L. The persistence of teaching laboratory effects into student teaching: A comparative study of verbal teaching behaviors and attitude. Paper presented at annual meeting of the American Educational Research Association, 1970.
- Bronfenbrenner, V. The experimental ecology of education. Educational Researcher, 1976, 5, 5-15.
- Copeland, W.D. The relationship between microteaching and student teacher classroom performance. Journal of Educational Research, 1975, 68, 289-293.
- Copeland, W.D. Some factors related to student teacher classroom performance following microteaching training. American Educational Research Journal, In Press, 1977.
- Copeland, W.D. & Doyle, W. Laboratory skill training and student teacher classroom performance. Journal of Educational Research, 1973, 42, 16-21.
- Doyle, W. & Ponder, G.A. Classroom ecology: Some concerns about a neglected dimension of research on teaching. Contemporary Education, 1975, 46, 183-188.
- Johnson, J.A. A national survey of student teaching programs. DeKalb, Illinois: Northern Illinois University, 1968.
- Peterson, T.L. Microteaching in the preservice education of teachers. Journal of Educational Research, 1973, 67, 34-36.



Figure 1. Research Design

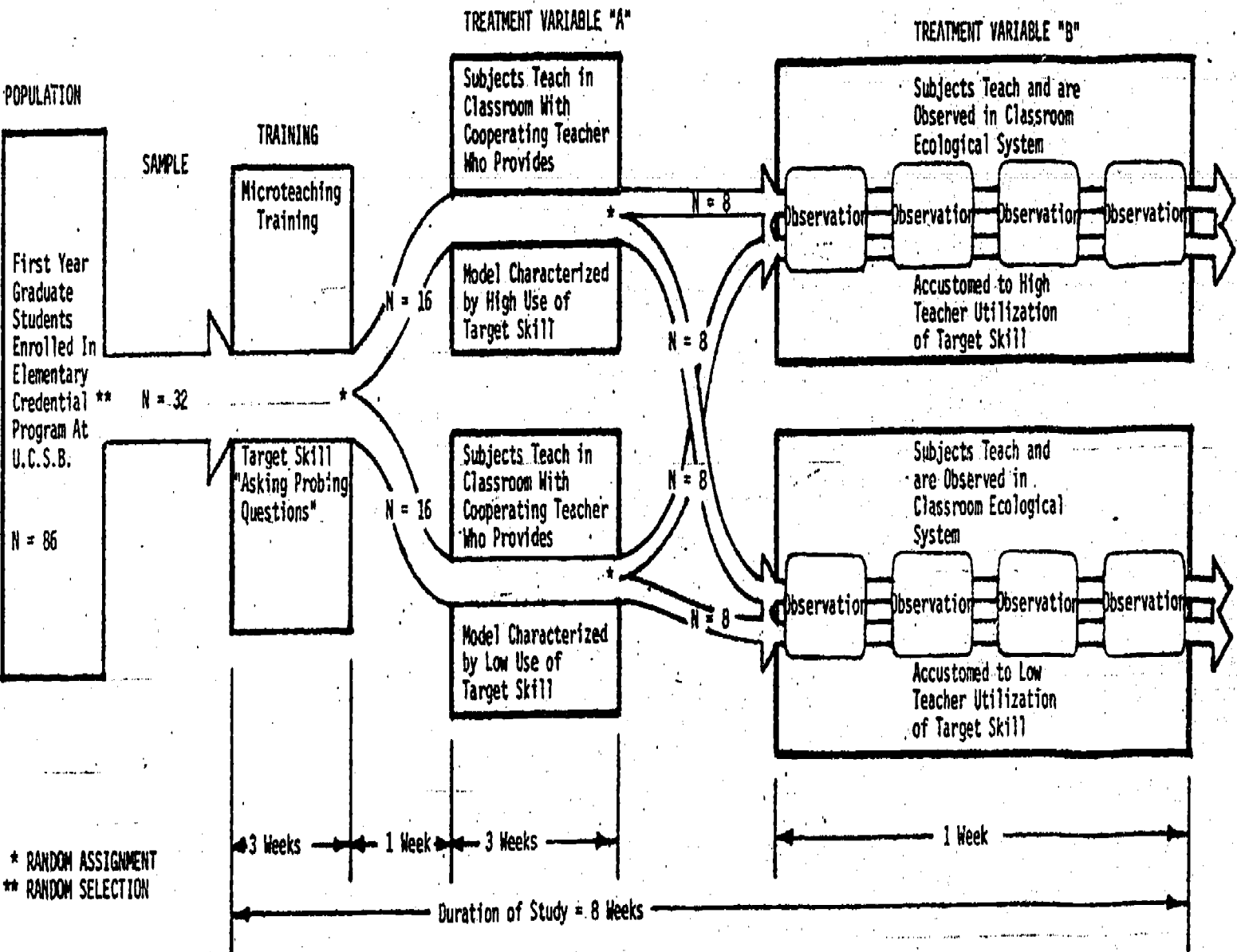

TABLE 1

Mean Skill Utilization Scores of Subjects Assigned to Two Levels of Each Independent Variable (N = 8 for each group)

Variable "A"	Variable "B"		Overall
	Subject teaches in classroom ecological system		
Cooperating teacher	which is accustomed to use of the target skill	which is not accustomed to use of the target skill	
provides model of use of target skill to subject	mean = 2.132 sd = 1.572	mean = 1.068 sd = 0.753	1.600
does not provide model of use of target skill to subject	mean = 1.710 sd = 1.479	mean = 0.939 sd = 0.674	1.325
Overall	1.921	1.003	1.462

TABLE 2

Summary of Analysis of Skill Utilization Scores

Source	df	MS	F
Model of Target Skill (A)	1	0.605	0.426
Classroom ecological system (B)	1	6.732	4.739*
Interaction (A X B)	1	0.171	0.120
Unit	28		

\*p<.05